

Double-Lid Cases

Features and Benefits

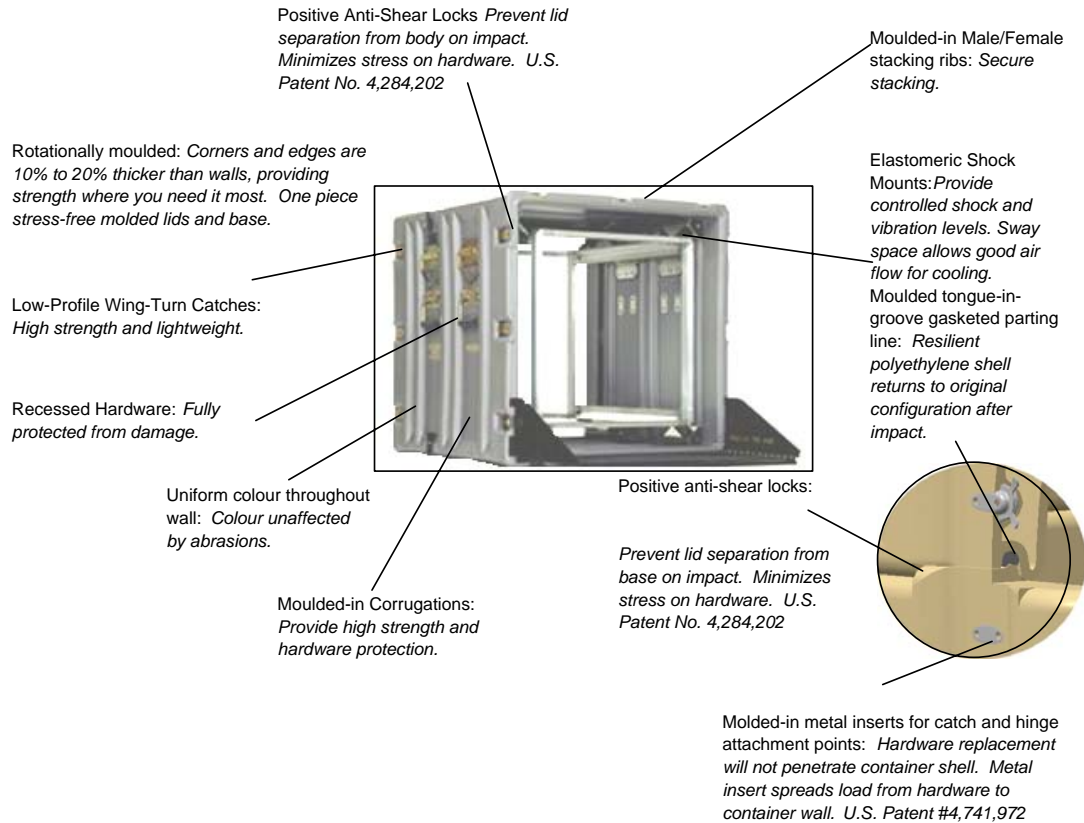

LIGHTWEIGHT AND RUGGED: Rotationally moulded double lid 19" rack cases reduce shipping costs and earn respect even after rough handling. Designed to meet ANSI/EIA-310-C for rack mount equipment. Airtight seals keep out humidity, sand, and chemicals. Long field life expectancies of 8+ years lower replacement costs and reduce down time. Colour will not peel off or scrape away. Interlocking ribs in the case body permit different sizes of cases to be stacked securely, with fronts aligned flush. Double entry design allows convenient front and rear access.

Test results verify that Hardigg rack cases exceed Air Transport Association (ATA), Specification 300, Category I requirements.

The finest engineering in off-the-shelf rack case sizes.

Double-Lid Cases

Measuring Guide

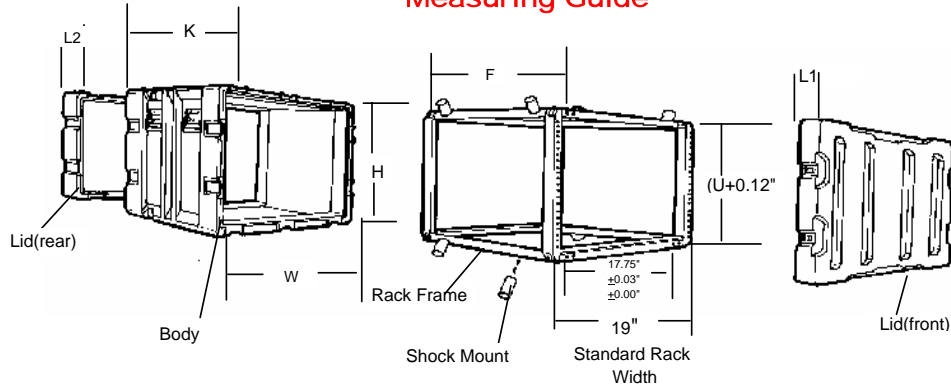

EXAMPLE:

CASE SIZE NUMBER

DE 24 12 - 02 / 24 / 02

Please note all dimensions are nominal.

L2 = Lid (rear) Interior Depth (2.5 or 5.25 inches/63 or 27mm)
(Rear)(for exterior dim. Add 1.25"/32mm)

K = Case Body Interior Length (24"/610mm)(for exterior dim. Add 0")

L1 = Lid (front) Interior Depth (2.5 or 5.25 inches/63 or 127 mm)(Front)

H = Case Body Interior Height (12"/305mm)(for exterior dim. Add 3"/76mm)

W=Case Body Interior Width (24"/610mm)(for exterior dim. Add 3"/76mm)

Double Lid (End/Entry)

U=1.75(inches)(44.45mm) i.e. 6U=10.50 inch/267 mm plus 0.12"(3mm)=(10.62"/270mm)
inside rack height

		ie: (when K is 27" then F is 25")					ie:(when K is 685mm then F is 635mm)				
CASE BODY LENGTH	K	27"	24"	30"	18"	25"	685	610	762	457	635
RACK LENGTH	F	25"	20"	28"	17"	23"	635	508	711	431	584

Double-Lid Case Options

Castors with Mounting System

Hardigg-engineered castor mounting system enhances the bottom panel strength of rack cases, while providing the same button-release convenience of the FastClip™ castor plate available on Single Lid cases. Castors (swivel style only) are Colson or equivalent brand, available in removable or fixed 3.5-inch or 5.0 inch wheel diameters. Systems consist of four castors, two machined aircraft aluminium extrusions, and mounting hardware installed on the bottom of the case.

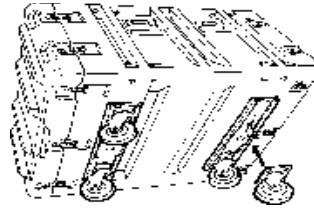

Recessed castor mounting extrusions are available for all DE sizes except DE2121-XX/18/XX, DE2121-XX/30/XX, DE2418-XX/20/XX and DE2652-XX/25/XX. Non-recessed extrusions can be installed on these four sizes.

Drawers

19" rack-mountable drawers are 14 inches (356 mm) deep and key-lockable. Complete with drawer-slides. Available in 2U, 3U, and 4U unit heights (U=1.75") (U=44.45mm).

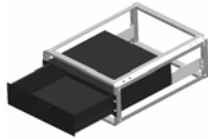

Rack Slides

Compact solid bearing slides. May be used to mount equipment directly into rack, or to mount drawers and shelves. Steel. Available in standard duty, 85 pound capacity. Sold in pairs.



Keyboard Tray

Accommodates standard size keyboard. 24 inches (610 mm) wide, 12 inches (305 mm) deep. Attaches to case front catches.

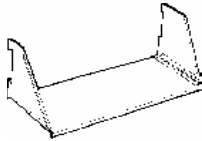

Two other models are available. One with a mouse tray and one that folds in half for compact storage. Please consult with your CSR.

Bezel Plate

Blank bezel plates in 16 gauge aluminum. Flanged for strength. Brushed black anodized finish. Available in 1U, 2U, 3U, and 4U unit heights (U=1.75")(44.45mm).

Castor Store-In-Lid-Kit

Removable castors are securely stored in lid using Hardigg FastClip™ (storage plate) mounting plate system (for 5" lids only (127 mm)).

Lid Hangers

Used to store lids conveniently on side of case when case is open. A set of four hangers for two lids.

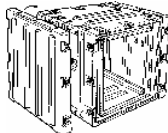

Double-Lid Case Options

Case Colours

Hardigg standard case colour is Gray 133 (FED-STD-595, #26270). The FED-STD and Pantone chip numbers listed are approximate and may vary slightly for multiple production runs. For a small additional per-case charge (for case quantities below 10), the following colors are available: () = Reference

Hardigg #	(FED Chip #)	Hardigg #	(Fed Chip #)	Hardigg #	(Pantone #)
133 Gray(Std)	26270	131 Yellow	23538	136 Yellow	Pantone 012U
101 Blue[Drk]	25052	132 White	27925	129 Purple	Pantone 245U
134 Orange	12197	130 Red	21105	197 Maroon	Pantone 202U
138 Green[Frst]	24052	032 Black	27040	135 Blue[Lt]	Pantone 292U
250 Tan[Sand]	20372	137 OD	34096		

Storage Pouch

Zippered pouch for storing cables and accessories in front and/or rear lids.

Comes mounted in lid.

Recommended for 5" lids.

Three sizes: 10" x 22" x 2.5" (254 x 559 x 63 mm) and 16" x 22" x 2.5" (406 x 559 x 63mm) and 18" x 18" x 2.5"(457 x 457 x 63mm).



Humidity Indicator

Indicates 20%, 30%, and 40% relative humidity ranges. Three part face changes colour when inside humidity exceeds the indicated level. As humidity reduces, the indicator resets for future use. Recommended for use with airtight cases



Locking Cable/Hasp

Allows the case to be padlocked shut. The cable is made of tamper-resistant aircraft steel. (Order two (2) each for each lid.) (4 per case)



Stainless Hardware

Standard zinc-plated yellow chromate hardware (catches, strikes, handles, hinges) is replaced by stainless-steel (clear passivated finish). Recommended for applications where zinc-plate is not suitable, such as excessive saltwater or chemical environments.

Card Holder

Metal holder for shipping-card, riveted to the exterior of case.

Size: 3" x 5" (76 x 127 mm).

Size: 4" x 6" (102 x 152 mm) can only be mounted on lids. Hardigg will determine best location.



Lifting Ring/Tie Down Ring

Welded ring provides hoisting and tie-down attachment points with two (2") inch (51 mm) diameter clearance for hooks. Ring is spring-loaded and pivots 180 degrees.

Available: Plated Steel
Stainless Steel
(1000 lb/ring rating)



Double-Lid Case Options

Extra Handle- 4 Hole

An extra 4-hole handle, mounted to your request on the case. Note: it is impossible to mount handles in some locations- check with Customer Service before ordering. Zinc-plate yellow chromate or Stainless steel (clear passivated finish).
(150 lb lift/handle)



Panel Screws

Used for mounting rack units, drawers, and blank bezel plates. #10-32, X 0.75 Lg screw with non-metallic washers for scratch protection. Set of 50.

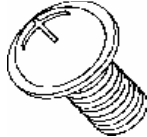

ATA Labels

(Air Transport Association)
Standard ATA container label set comply with Specification 300 Category I. Hardigg will specify color. Label set includes:

- Delicate Unit
- Handle with Care
- Up Arrows
- Label Opposite Side
- Place Label Here
- ATA Spec 300

Front Labels

Indexing labels - A set of two "front" labels are applied to the case: one on the mid section and one on the lid. Ensures that the lids are put back on in the proper orientation.

Coupling Catch

Convenient elastomeric devices to couple containers together vertically while stacked on top of each other to prevent accidental tip over.

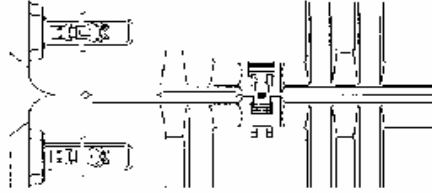

I.D. Plate

I.A.W. MIL-P-15024, Type H, Style IV, Size 10.
4" x 4" x .020" (102 x 102 x 0.5 mm) thick aluminum, fastener attached. Text font is News Gothic Bold. Please fill out our standard I.D. plate form. Call your Customer Service representative for lead time. (See layout form in the order form section.)



Double-Lid Case Options

Adjustable Side Support Rails or Fixed Bottom Support Rails

Two each 2 x 2 x 1/8 inch vertically adjustable support rails used to support equipment while installing.

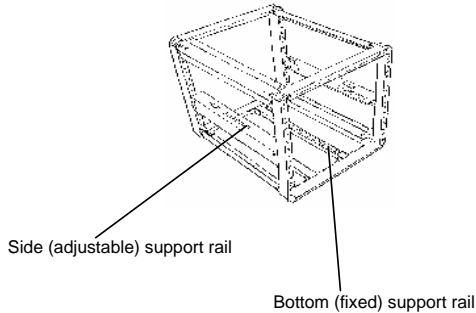

Rack Frame/Shock Mount Ordering Guideline

For Rack Cases with more than 170 pounds (77 Kg) of packaged equipment, sixteen (16) elastomeric shock mounts are used to suspend the rack in lieu of eight (8) mounts. With these heavier loads, vertical metal wall stiffeners are added to the case body in order to maintain dimensional control of the front and back openings. This assures that the covers will easily go back on to the case body and latch properly. Four delta lifting/tie down rings are also installed to provide mechanical lift accessibility.

Shelves, Fixed and Sliding

Shelves can easily be removed & customized to accommodate non-rack mountable equipment.

Epoxy Stencil

Per MIL-I-43553. Available colours are Black, White, and Yellow. Listed below are popular combinations of the case colour along with the corresponding ink colour. One ink colour per case. If not specified Hardigg will choose colour. Hardigg reserves the right to choose the stencil text or graphic size, font and location.

Black Ink used on case colours:

White	Orange	Yellow	Red
Olive Drat Lt. Blue		Dk Green	

White Ink used on case colours:

Dk Blue Black

Yellow Ink used on case colours:

Gray

Double-Lid Case Options

Airtight Case System - Definitions and Classifications

This option includes PRV ± 0.5 (35 mb) setting (with manual release button is recessed below cover rim) and gasketing/hardware required to safely maintain correct pressure differential. Available on all Double Lid Hardigg cases. Test pressure range: ± 0.25 PSID (18 mb).



CERTIFIED AIRTIGHT / WATERTIGHT

Level "A"

(Application - Military or high-end industrial packaging with uncontrolled environmental exposure.)

This container feature describes a custom, design numbered, container assembly with Pressure Relief Valve (PRV) or a catalogue configured container with the CERTIFIED AIRTIGHT / WATERTIGHT option selected. This type (Level "A") of sealed container is factory pressurized leak tested to an established Quality Control Sample Plan or 100 (%) percent leak test if specified. Both inspection levels are with recorded leak test results. Fill valves and Purge valves are available options on these containers. A certificate of Conformance is supplied with each shipment lot. (This performance level "A" is not available for all container styles. Refer to published literature or a Customer Service Representative for verification).

CONTROLLED BREATHER / SPLASHPROOF and RAINPROOF

Level "B"

(Application - COTS Military, general industrial packaging with intermittent environmental exposure.)

This container feature describes a custom, design numbered, container assembly with a Pressure Relief Valve (PRV) or a catalogue configured container with Standard Construction and the PRV option. This type (Level "B") of a totally gasketed container is inspected for workmanship and seal integrity but pressurized leak testing is not conducted.

FREE BREATHER / VENTED - (SPLASH AND RAIN RESISTANT) (normal upright position)

Level "C"

(Application - Industrial and Commercial packaging with controlled environmental exposure.)

This container feature describes a catalogue configurable container assembly or design numbered container that is vented to atmosphere via a gap in the lid gasket or other fabricated holes or devices in the container shell wall to prevent pressure / vacuum buildup. This type (Level "C") of Free Breathing container assembly is generally splash and rain resistant with the container in the normal upright position.

Performance of Double Lid Rack Cases

93FEB119
REF: TS-967
TS-983

PERFORMANCE OF DOUBLE LID RACK CASES

TEST RESULT TRENDS ON 70 AND 14 U RACK SIZES
HARDIGG RACK CASES HAVE TWO (2") INCHES (50.8 mm) DYNAMIC SWAY SPACE

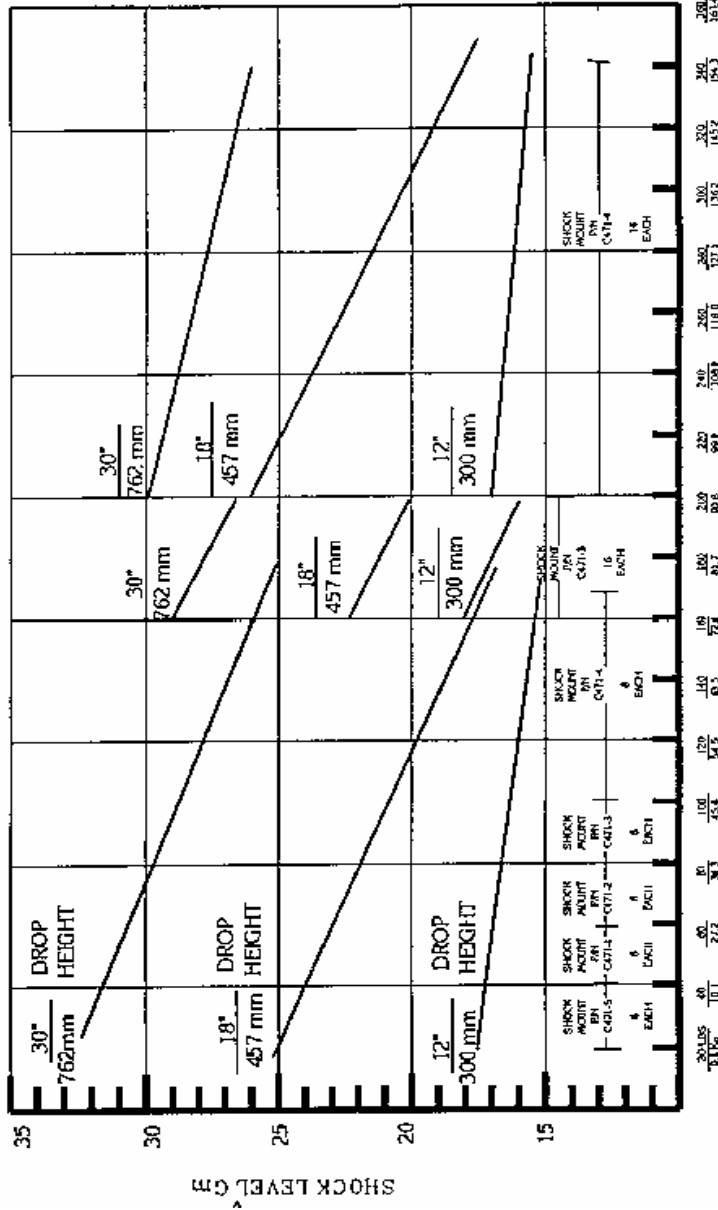
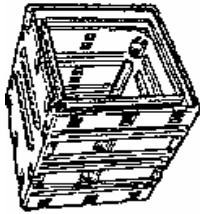

LOAD IN POUNDS (LBS)/KILOGRAMS (Kg) PER RACK